

# Levelling & Contouring

# Definition, Principle, & Object of Levelling

- *Definition:- Levelling is defined as “an art of determining the relative height of different points on, above or below the surface”.*

# Principle of levelling

- *Principle:- The principle of levelling is to obtain horizontal line of sight with respect to which vertical distances of the points above or below this line of sight are found.*

# Object of levelling

- *The objective of levelling is to*
- *1) Find the **elevation** of given point with respect to some assumed reference line called **datum**.*
- *2) To **establish** point at required **elevation** with respect to **datum**.*

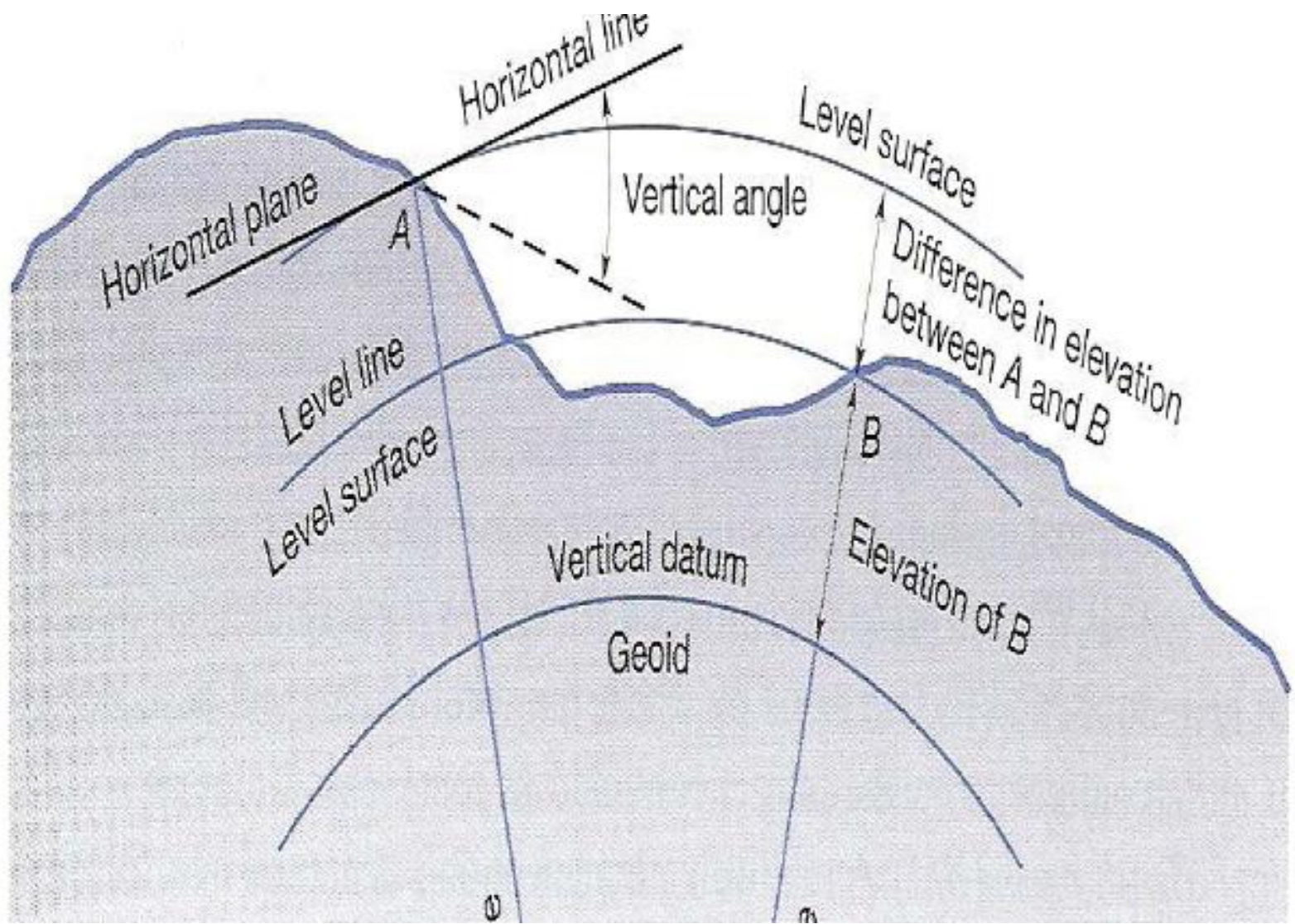

# Definitions used in levelling

- *Level surface*:- It is the surface parallel to the mean spheroidal surface of the earth
- *Level line*:- Line lying on level surface.
- *Horizontal plane*:- Horizontal plane through a point is a plane tangential to level surface.
- *Horizontal line*:- It is a straight line tangential to level line.

- *Datum*: - “It is an arbitrary level surface from which elevation of points may be referred”. In India mean sea level is considered as datum of zero elevation it is situated at Karachi.

*Mean sea level* is the average height of sea for all stages of tides it is derived by averaging the hourly tide height over a period of 19 years.

- *Elevation or Reduced level*: - It is height or depth of any point above or below any datum. It is denoted as R.L.

- *Bench Mark (B.M.):*- It is a fixed reference point of known elevation with respect to datum.
- *Line of collimation:*- It is a line joining the intersection of cross hairs of diaphragm to the optical centre of object glass and its continuation. It is also known as line of sight.
- *Height of instrument:*- It is the elevation of line of collimation with respect to datum
- *Back sight:*- It is a staff reading taken at a known elevation. It is the first staff reading taken after setup of instrument.



- *Fore sight( F.S.):*- It is the last staff reading taken denoting the shifting of the instrument.
- *Intermediate sight.(I.S.):*-It is staff reading taken on a point whose elevation is to be determined. All staff reading between B.S. and F.S. are Intermediate sight.
- *Change Point:*- It is a point on which both fore and back sight are taken.

# Instruments for levelling

- *The following instruments are essentially required for levelling*
- *Level*
- *Levelling staff*

# Level and types of level

- *Level:- The instrument used to furnish horizontal line of sight for observing staff readings and determining R.L.s*
- *Types*
- *Dumpy level*
- *Tilting level*
- *Wye level*
- *Automatic level*

# Dumpy level

- *The Dumpy level is a simple, compact and stable instrument. The telescope is rigidly fixed to its supports. Hence it cannot be rotated about horizontal axis.*



# Tilting level

- *It is also known as I.O.P. level (Indian office Pattern). In this level the telescope tilts about its horizontal axis hence it is called tilting level*

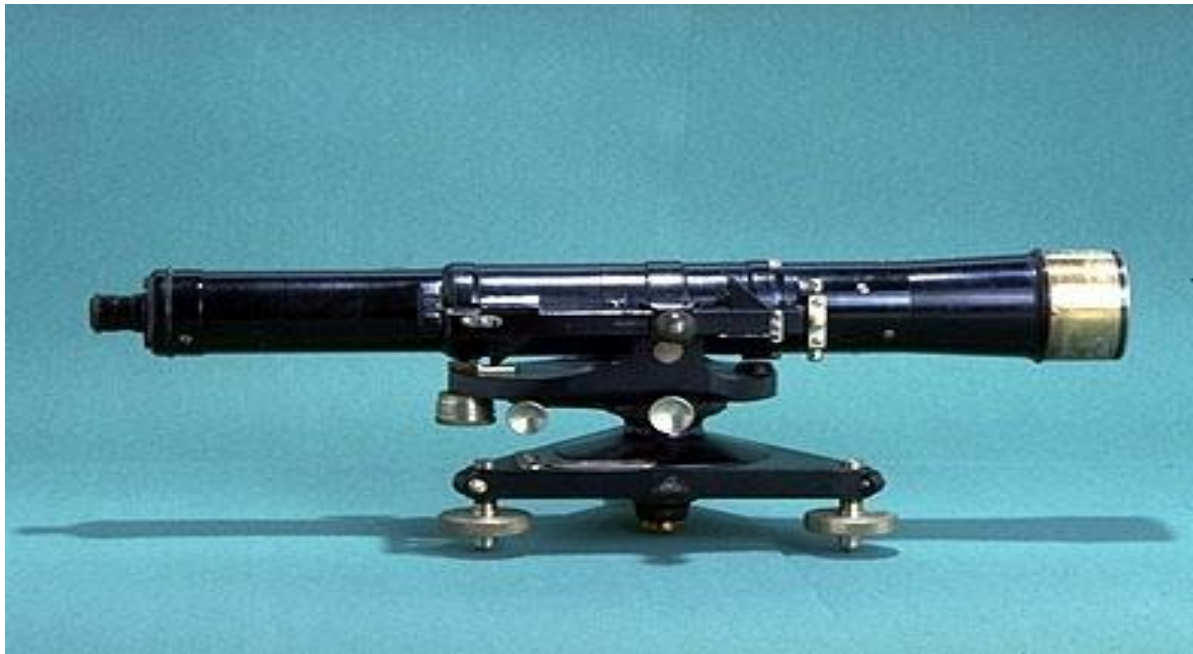

# Wye level

- *The essential difference between wye level and other levels is that in wye level the telescope is carried by two vertical wye supports. The telescope can be rotated, moved or even raised in wyes.*

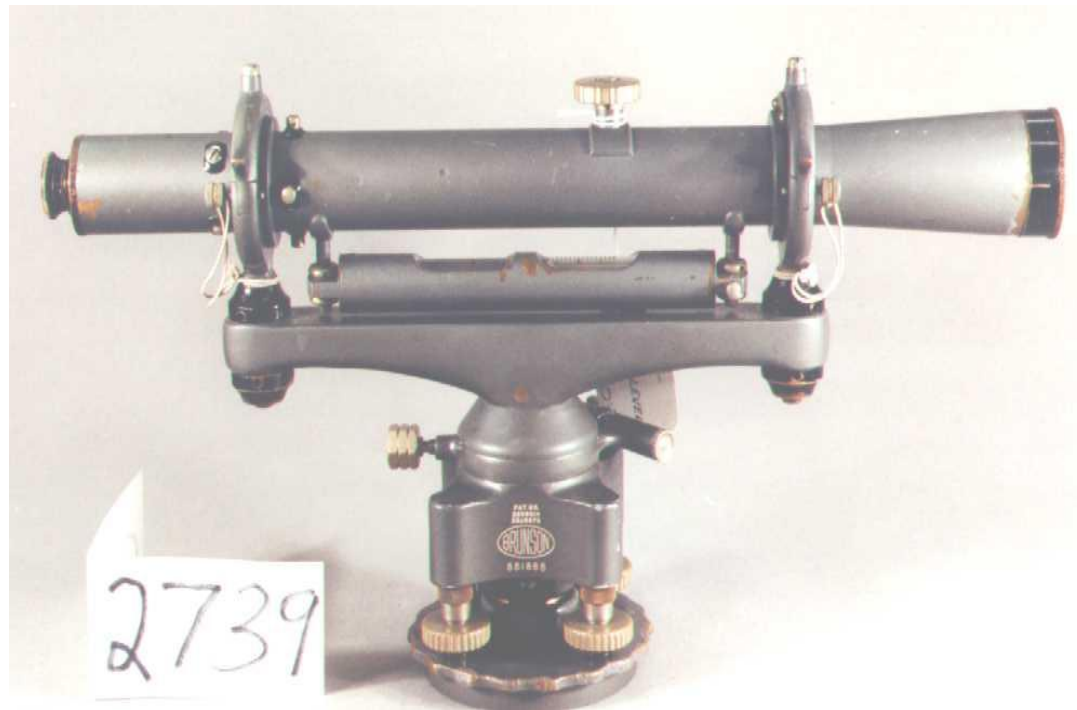

# Automatic level

- *It is also known as self aligning level. It is a recent development. The fundamental difference between auto level and other levels is that the levelling is not manually but it is levelled automatically. It is achieved by inclination compensating device.*



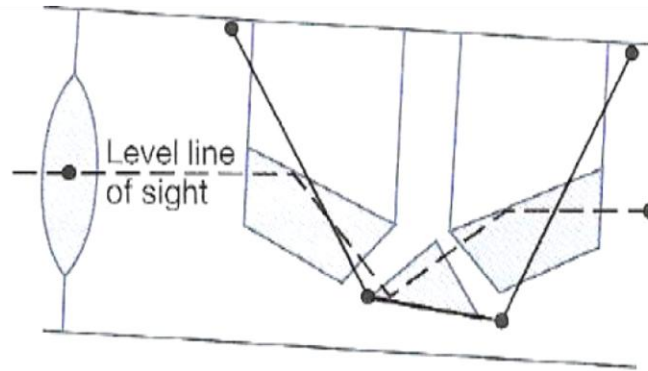

When telescope tilts up, compensator swings backward.

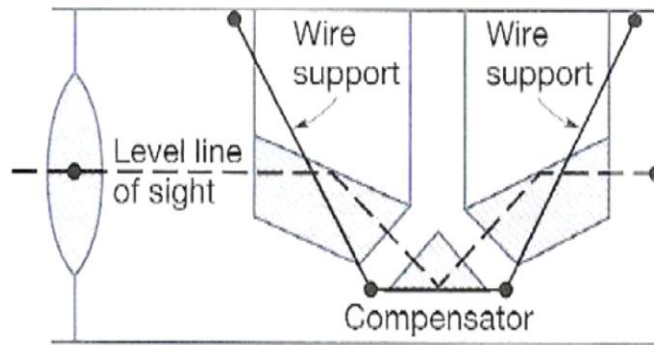

Telescope horizontal

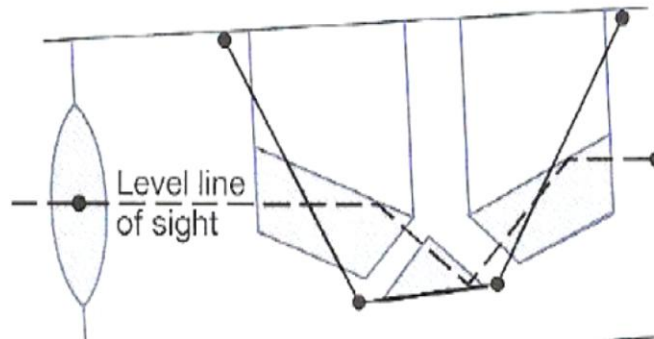



# Levelling Staffs

- *Levelling staffs are scales on which these distances are measured.*
- *Levelling staffs are of two types*
- *Self reading staff*
- *Target staff*

# Self reading staff

- *The self reading staff can be read directly by the level man looking through the telescope.*
- *Common types of self reading staffs*
- *Ordinary staff*
- *Sopwith telescopic staff*
- *Folding Staff*



# Target staff

- *For very precise works and sight target staff are used. A movable target is provided in this staff. A vernier is provided on target to give precise reading. In target staff level man directs the staff man to move the target up and down until it bisects by the line of sight. The staff man observe the staff reading*

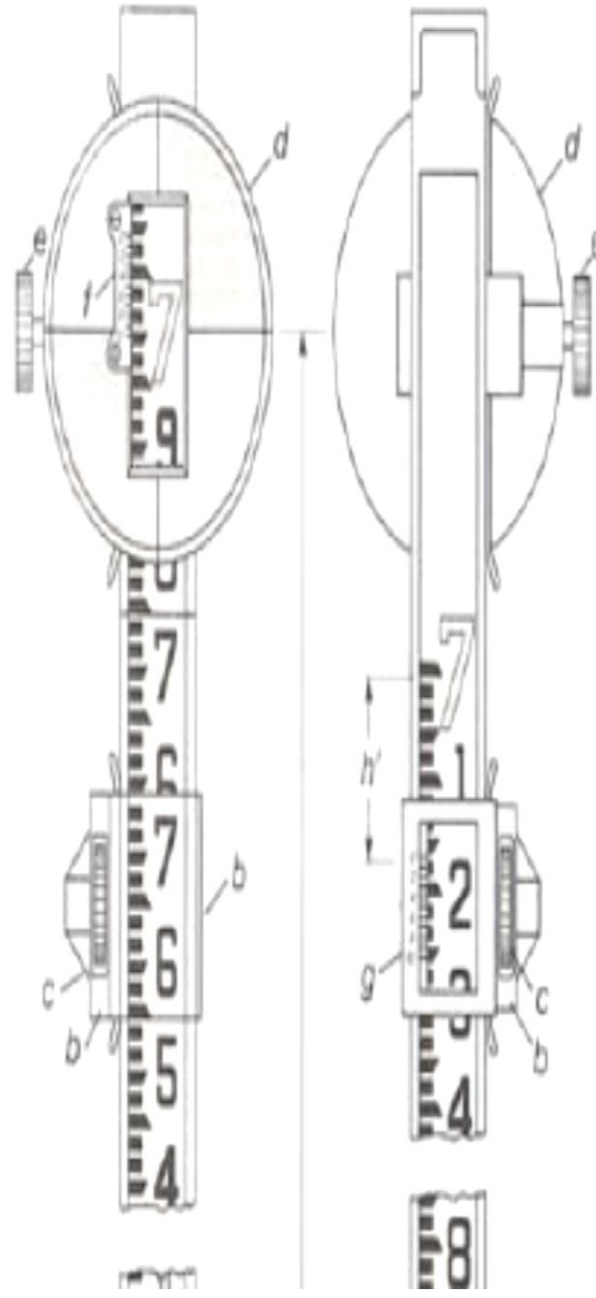

# Bench Marks

- *Bench mark is a point of known elevation*
- *There are 4 kinds of bench marks*
- *GTS (Great trigonometrically survey bench mark)*
- *Permanent bench mark*
- *Arbitrary bench mark*
- *Temporary bench mark*

# GTS Bench mark

- *They are the bench marks established with very high degree of precision at regular intervals by the survey of India Department all over the country Their position and R.Ls values above mean sea level at Karachi are given in catalogue formed by the department.*
- *Mean sea level*



# Permanent Bench mark

- *Permanent bench marks are fixed in between GTS bench marks by govt. agencies such as railways, PWD, etc. This bench marks are written on permanent objects such as milestones, culverts, bridges etc their value are clearly written and their position are recorded for future reference.*



- *Arbitrary bench marks:-* These are reference points whose R.L.s are arbitrarily assumed. They are used in small works such bench mark may be assumed as 100. or 50 m
- *Temporary bench marks:-* They are the reference points established during the levelling operations when there is a break in work, or at the end of day's work the value of reduced levels are marked on some permanent objects such as stones, trees etc.



# Temporary Adjustments of a level

- *These adjustments are performed at every setup of instrument*
- *Setting up of level*
- *Levelling of telescope*
- *Focusing of the eye piece*
- *Focusing of object glass*

- *Setting up the level:- This includes*
- *A) Fixing the instrument on tripod*
- *B) Levelling the instrument approximately by Tripod*
- *Levelling:- Levelling is done with the help of foot screws. The purpose of levelling is to make vertical axis truly vertical. It is done with the help of foot screws*
- *A) Place the telescope parallel to a pair of foot screw then hold the foot screws between thumb and first finger and turn them either inward or outward until the longitudinal bubble comes in the centre.*
- *B) Turn the telescope through  $90^{\circ}$  so that it lies parallel to third foot screw, turn the screw until the bubble comes in the centre.*

- *Focusing the eye piece:- To focus the eye piece, hold a white paper in front of object glass, and move the eye piece in or out till the cross hair are distinctly seen.*
- *Focusing of object glass:- Direct the telescope to the levelling staff and on looking through the telescope, turn the focusing screw till the image appears clear and sharp.*

# Classification of levelling

- Simple levelling
- Differential leveling
- Fly levelling
- Check levelling
- Profile levelling
- Cross levelling
- Reciprocal levelling
- Precise levelling
- Trigonometric levelling
- Barometric levelling
- Hypersometric levelling

- *Simple levelling*:- It is the simplest method used, when it is required to find the difference in elevation between 2 points.

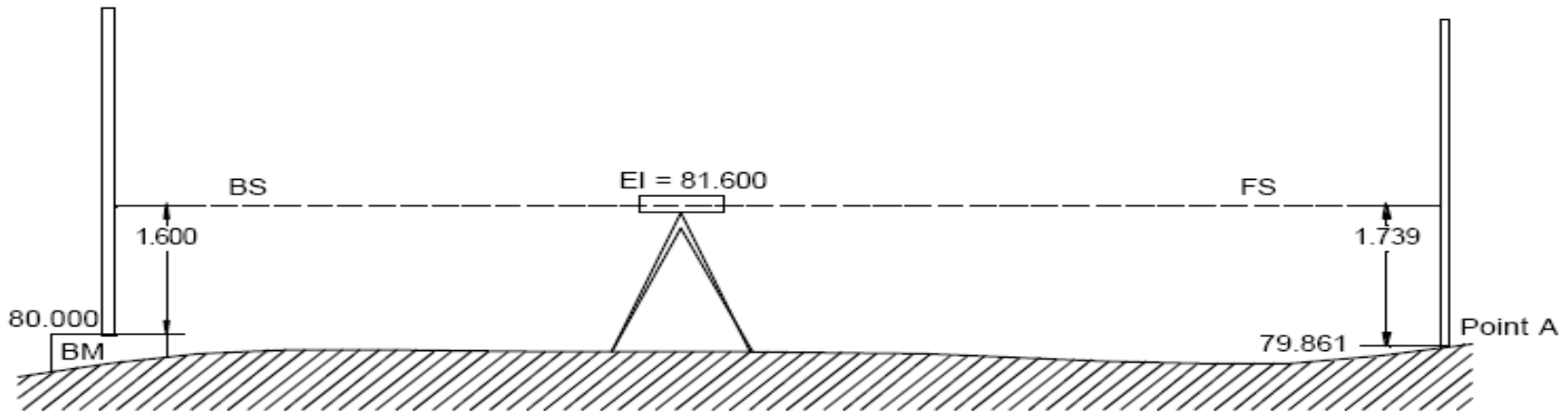

- *Differential Levelling*:- This method is used to find the difference in the elevation between points if they are too far apart or the difference in elevation between them is too much.

# Computation of Elevations

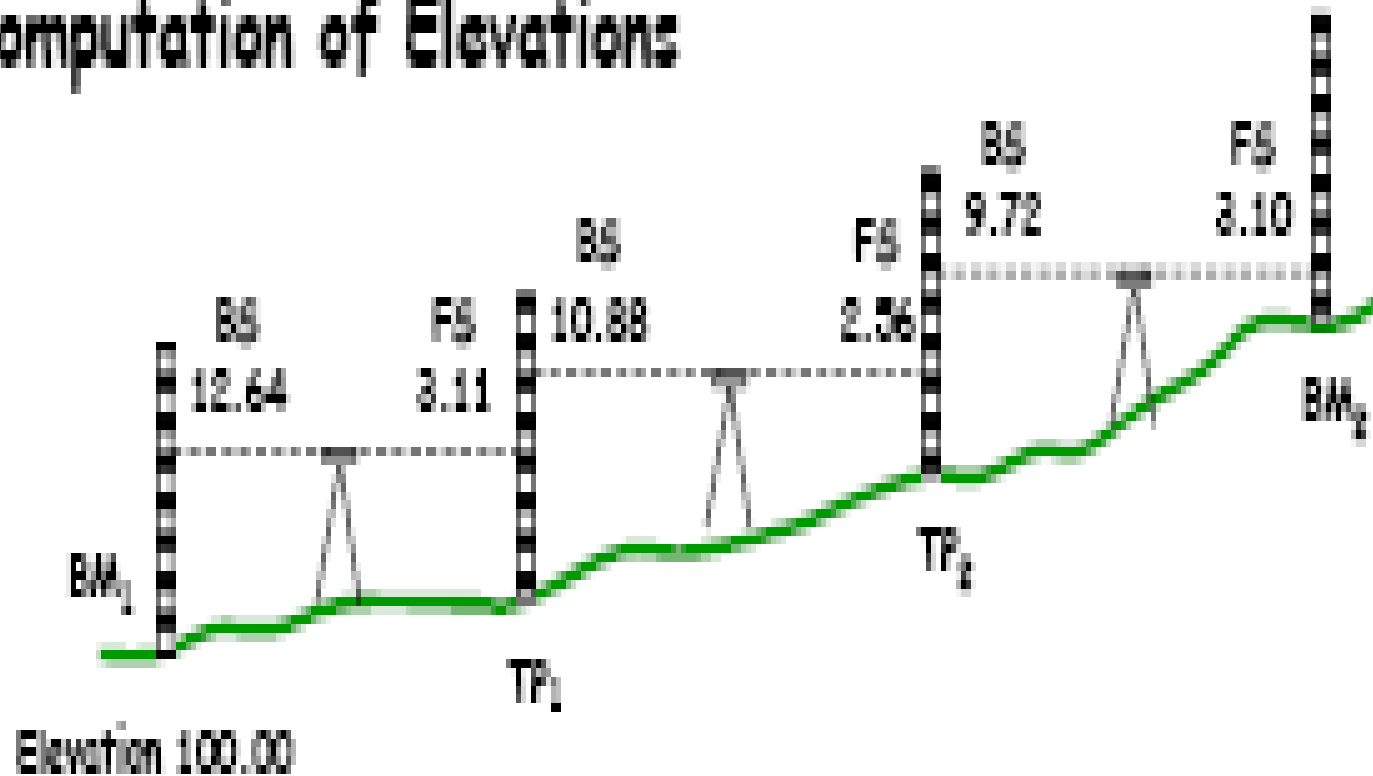

- *Fly levelling*:- Fly levelling is just like differential levelling carried out to check the accuracy of levelling work. In fly levelling only B.S. and F.S. are taken

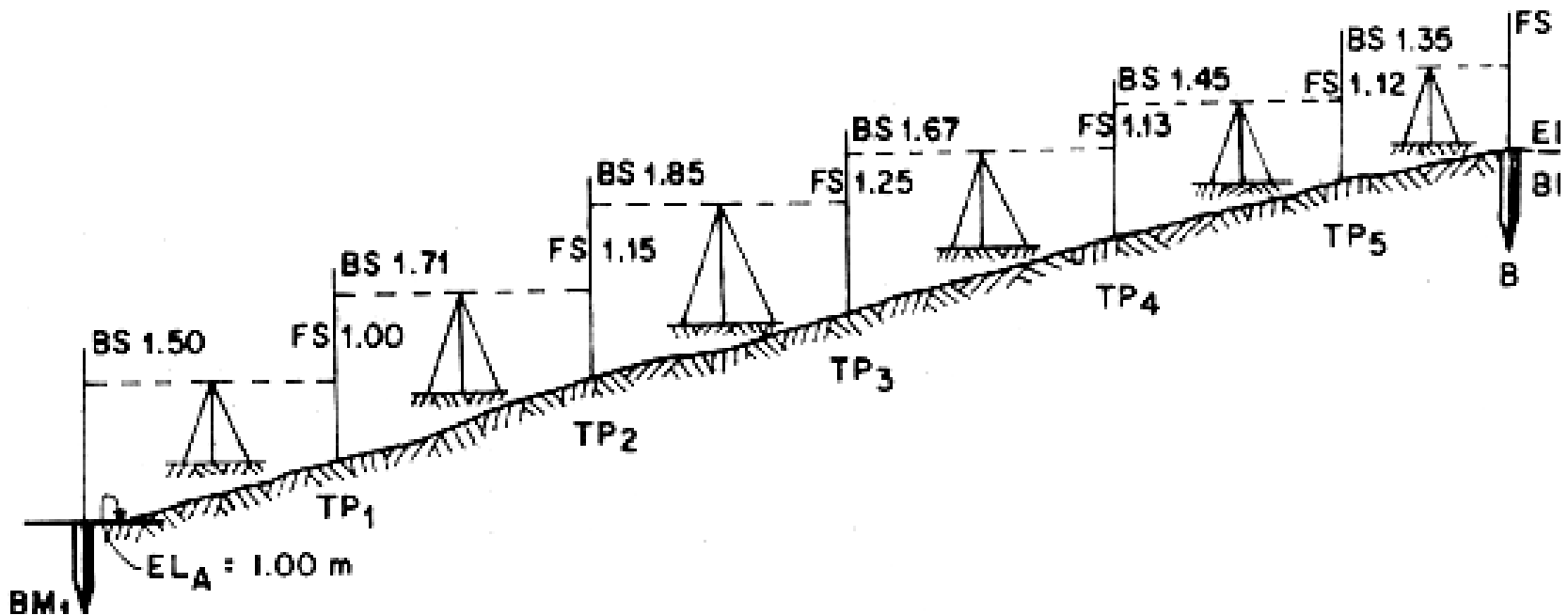

- *Check levelling*:- This kind of levelling is carried out to check the accuracy of work. It is done at the end of the days work in the form of fly levelling to connect the finishing point and starting point.
- *Profile levelling or L-Section*:- This method is used for taking levels along the centre line of any alignment like road, railway canal etc. The object is to determine the undulations of the ground surface along the alignment



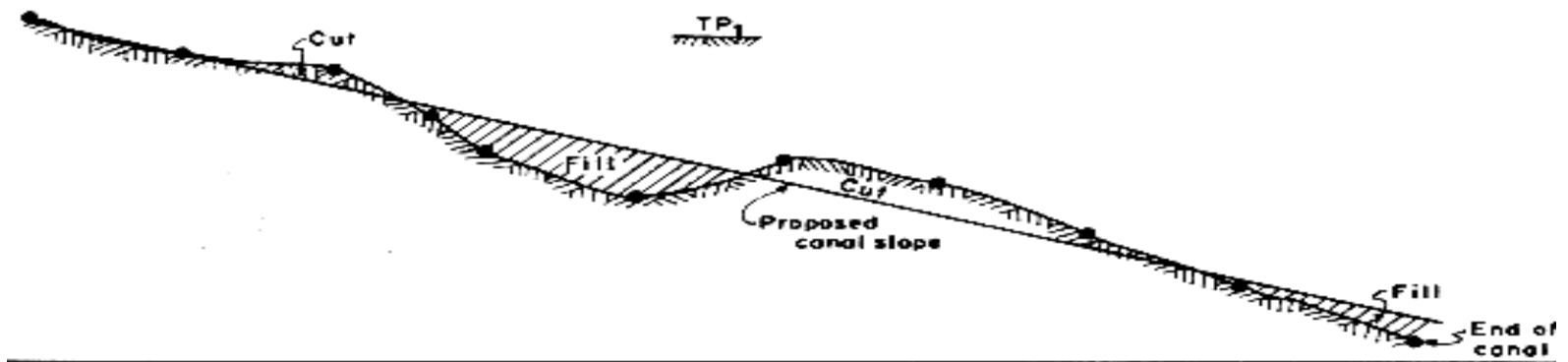
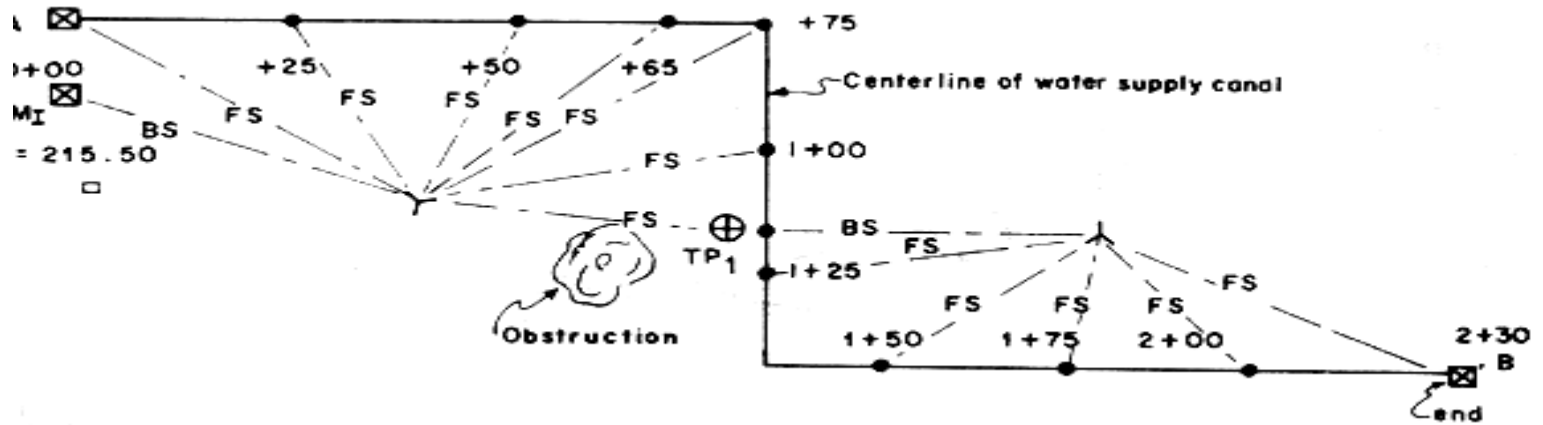

- *Cross- sectioning*:- This operation is carried out perpendicular to alignment at an interval of 10, 20 ,30, 40 m. The idea is to make an estimate of earthwork.
- *Precise levelling*:- It is used for establishing bench marks for future public use. It is carried out with high degree of accuracy using advanced instruments
- *Trigonometric levelling*:- In this method vertical distances between points are computed by observing horizontal distances and vertical angle between points.

- *Barometric levelling:- In this method the altitude difference is determined by means of a barometer.*
- *Hyposometric levelling:- The working of Hyposometry for determining the elevation depends upon the fact that the temperature at which water boils varies with the atmospheric pressure. The boiling point of water reduces at higher altitude thus knowing the boiling point of water, the atmospheric pressure can be calculated and knowing the atmospheric pressure altitude or elevation can be determined*

# Reciprocal levelling

- **Reciprocal levelling**:—This method is adopted to accurately determine the difference of level between two points which are far apart. It is also used when it is not possible to set up level in mid way between two points
- Let A and B be the two points on opposite banks of a river. It is required to find out the level difference between A & B
- Set up the level very near to A and take the reading at A and B let the reading be  $a_1$  and  $b_1$
- Shift the level and set up very near to B and observe A and B to get reading  $a_2$  and  $b_2$
- Let  $d$  is the true difference of level between A and B, and  $e =$  error due to curvature, refraction and imperfect adjustment.

- Thus to eliminate the error take an average of the difference in elevation taken from 2 points
- i.e. from A the true difference will be  $= (b1' - e) - a1$
- From B the difference will be  $= b2 - (a2' - e)$
- Therefore  $d = \{ (b1' - a1) + (b2 - a2') \} / 2$

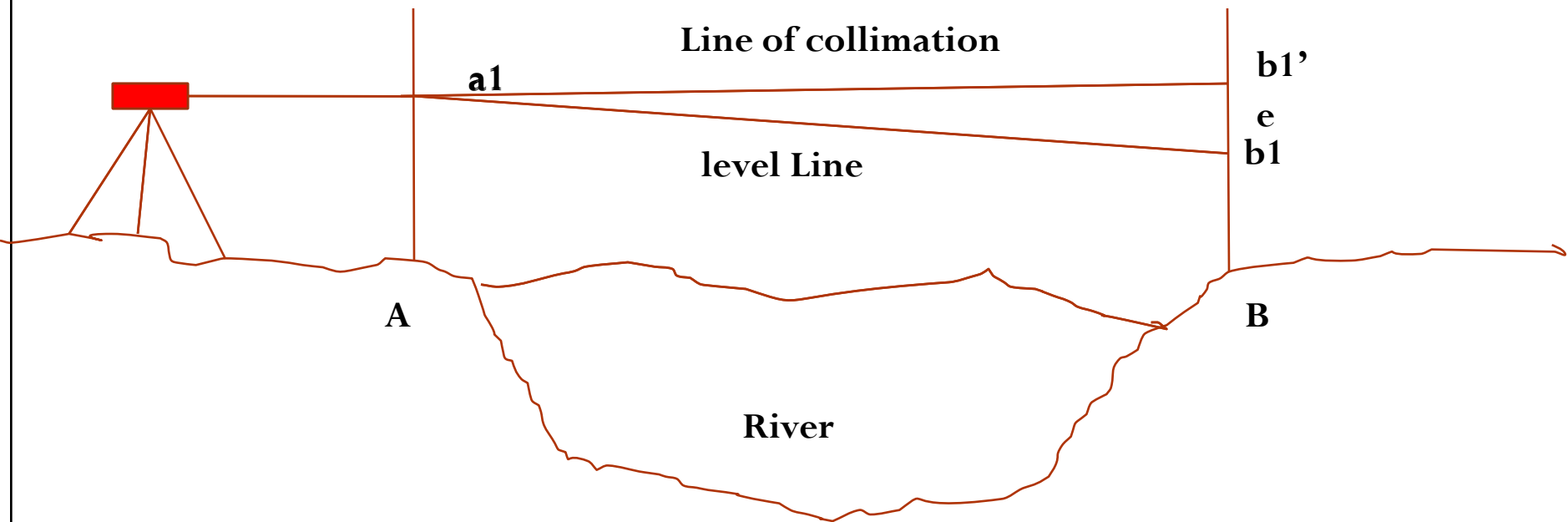

- Thus to eliminate the error take an average of the difference in elevation taken from 2 points
- i.e. from A the true difference will be  $= (b1' - e) - a1$
- From B the difference will be  $= b2 - (a2' - e)$
- Therefore  $d = \{(b1 - a1) + (b2 - a2)\} / 2$

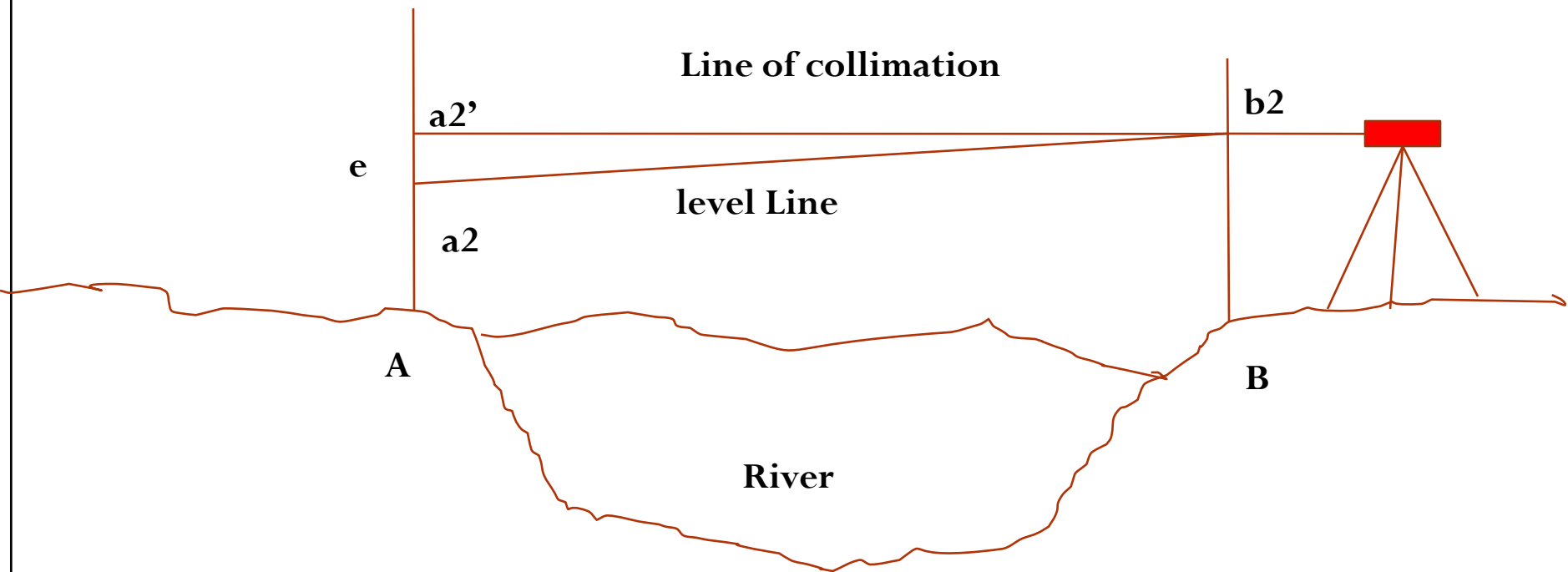

# Methods of Reducing levels

- *Height of Instrument Method:- This method consist of finding H.I. for every setup of instrument, and then obtaining the R.L. of point of reference with respect to H.I*

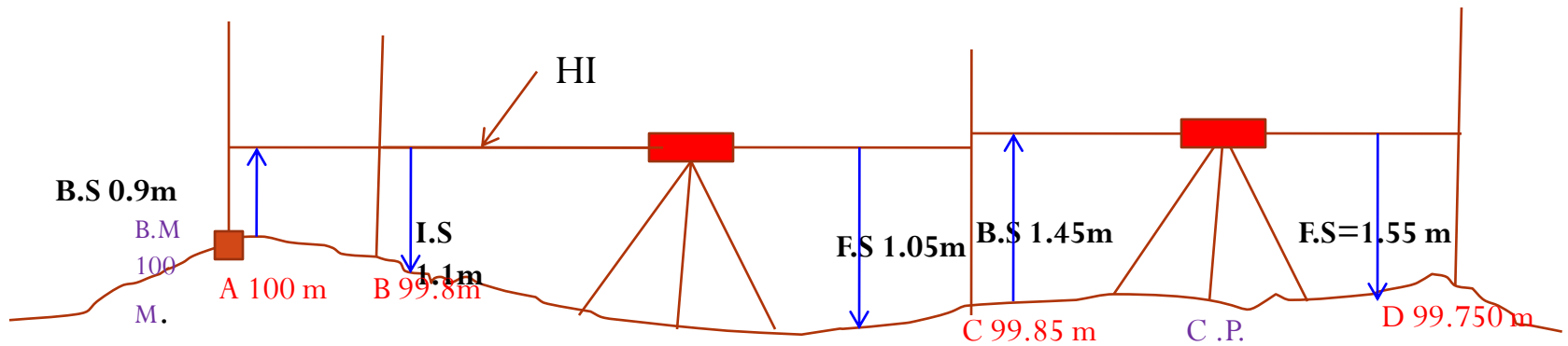

Station	B.S	I.S	F.S	H.I	R.L	Remark
A	0.9			100.9	100.00	B.M
B		1.1			99.800	
C	1.450		1.05	101.3	99.850	C.P.
D			1.550		99.750	



# Rise and fall method

- *This method consist of determining the difference of level between consecutive points by comparing each point with immediate preceding point.*



# Example

- The following staff readings were observed successively with a level the instrument is moved by third sixth and eighth readings.
- : 2.228 :1.606 :0.988 :2.090 :2.864 :1.262 0.602 :1.982 :1.044 :2.684 m enter the reading in record book and calculate R.L. if the first reading was taken at a B.M of 432.383m

# H.I. Method

Station	B.S	I.S	F.S	HI	RL	REMARKS
1	2.228			434.612	432.384 M	B.M.
2		1.606			433.006	
3	2.090		0.988	435.714	433.624	3 <sup>RD</sup> C.P.
4		2.864			432.850	
5	0.602		1.262	435.054	434.452	6 <sup>TH</sup> C.P
6	1.044		1.982	434.116	433.072	8 <sup>TH</sup> C.P
7			2.684		431.432	
	5.964		6.916			

**CHECK**  $\sum \text{B.S} - \sum \text{F.S} = 5.964 - 6.916 = -0.952 = \text{LAST R.L} - \text{FIRST R.L} = 431.432 - 432.384 = -0.952$

# Rise and fall method

Station	B.S	I.S	F.S	Rise	Fall	RL	REMARKS
1	2.228					432.384 M	B.M.
2		1.606		0.622		433.006	
3	2.090		0.988	0.618		433.624	3 <sup>RD</sup> C.P.
4		2.864			0.774	432.850	
5	0.602		1.262	1.602		434.452	6 <sup>TH</sup> C.P
6	1.044		1.982		1.38	433.072	8 <sup>TH</sup> C.P
7			2.684		1.64	431.432	
	5.964		6.916				

**CHECK**  $\sum \text{B.S} - \sum \text{F.S} = 5.964 - 6.916 = -0.952 =$   
 $\text{LAST R.L} - \text{FIRST R.L} = 431.432 - 432.384 = -0.952$   
 $\sum \text{RISE} - \sum \text{FALL} = 2.842 - 3.794 = -0.952$

# Contour

*A contour is an imaginary line joining points of equal elevation*

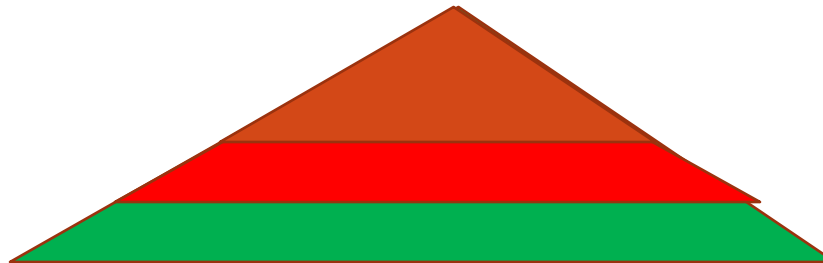
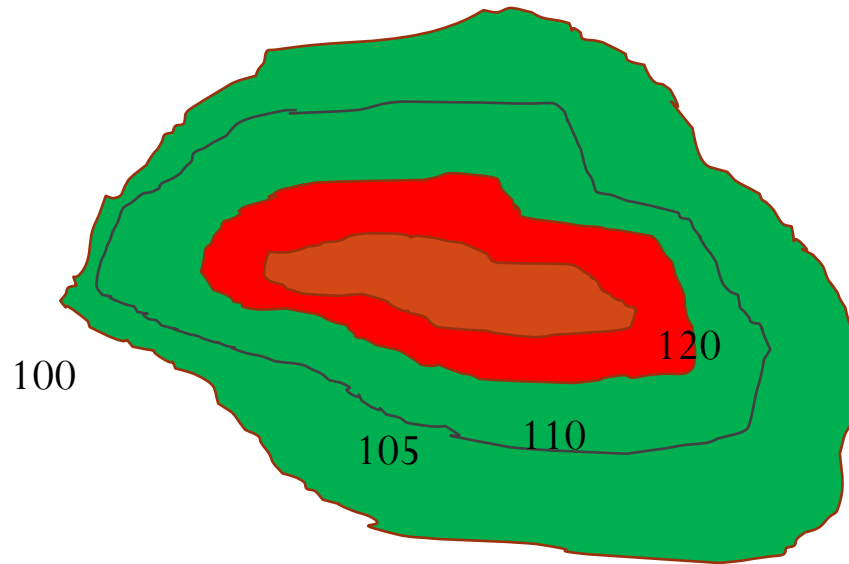

# Contour Interval

- *The vertical distance between any two consecutive contours is known as contour interval*

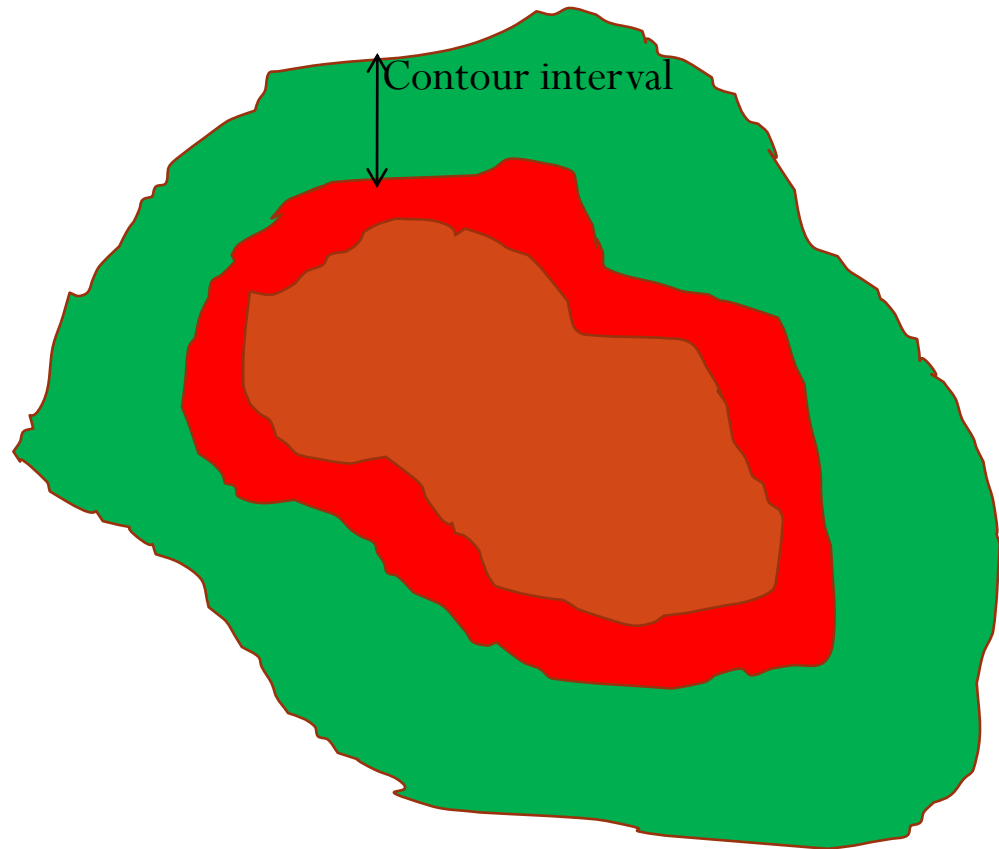

# Characteristics of contour lines

- *A series of contour lines with higher value inside indicate a hill*
- *A series of contour lines with lower value inside the loop always indicate depression*
- *Close contour lines indicate steep slope*
- *Wide contour lines indicate flatter slope*
- *Contour lines never cross each other except in case of overhanging cliff.*
- *All points on a contour lines have equal elevation*



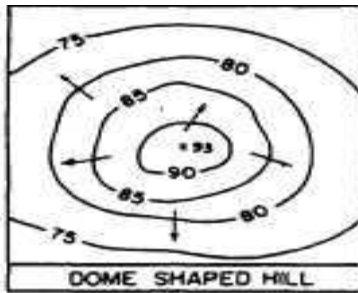

DOME SHAPED HILL

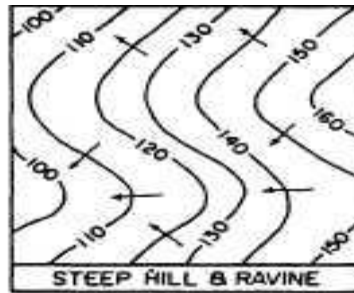

STEEP HILL & RAVINE

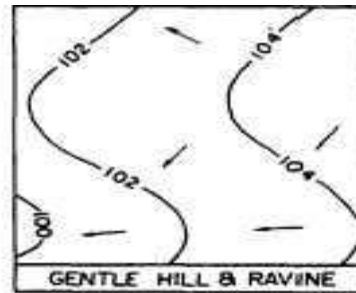

GENTLE HILL & RAVINE

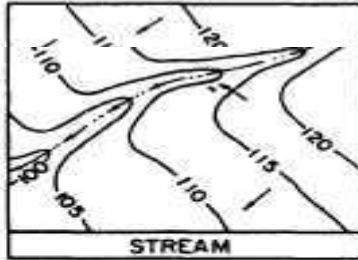

STREAM

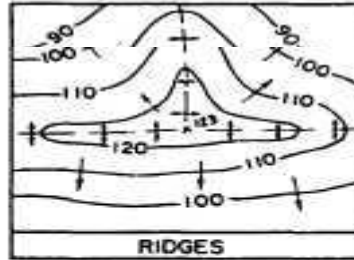

RIDGES

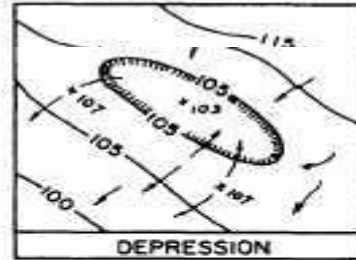

DEPRESSION

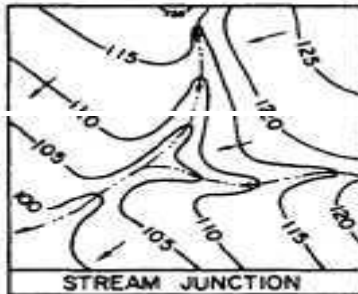

STREAM JUNCTION

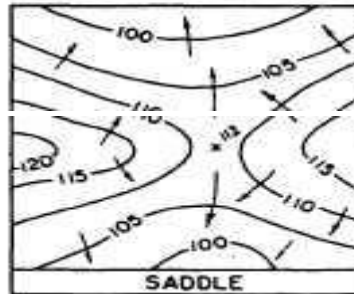

SADDLE

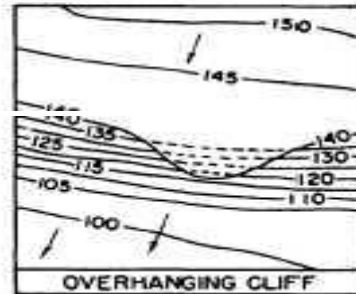

OVERHANGING CLIFF

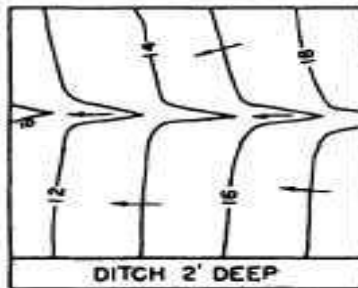

DITCH 2' DEEP

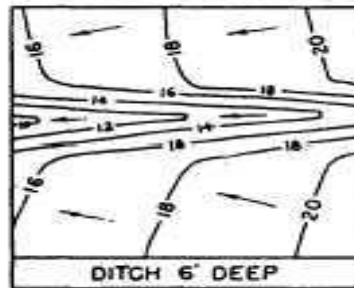

DITCH 6' DEEP

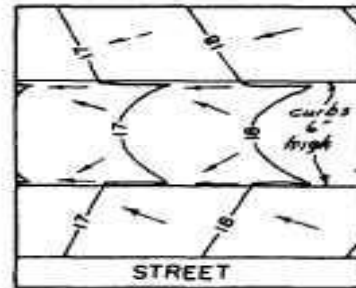

STREET

# Uses of Contours

- *The nature of ground surface of a region can be known*
- *Contour map helps in locating proper **site** for **bridges, dams, reservoirs etc.***
- ***Capacity of a reservoir** can be calculated with the help of contour map*
- *The quantity of **cutting and filling** can be determined from contour maps.*
- ***Routes** for roads, railways, canals etc can be traced.*

# Errors in Levelling

- *The following are the different sources of Errors*

- ***Personal Error***

- *The Instruments may not be leveled*
- *The focusing of eye piece and objective glass may not be perfect*
- *The parallax may not be eliminated*
- *The position of staff may have changed*
- *Entry and recording in the field book may not be correct*
- *The staff may not be fully extended, may not be held vertical.*

- ***Instrumental Error:***

- *The Permanent adjustment of the instrument may not be perfect. That is the line of collimation may not be horizontal line*
- *The internal arrangement of focusing tube may not be correct*
- *The graduation of the staff may not be perfect*

- ***Errors due to Natural Causes:***

- *The Curvature of the Earth may affect the staff readings when the distance of sight is long.*
- *The effect of refraction may cause a wrong staff reading*
- *There are some errors in staff readings due to high velocity wind.*

# Curvature Correction

- For long sights the curvature of earth can effect staff readings. The line of sight is horizontal but the level line is curved and parallel to the mean spheroidal surface of the earth. The vertical distance between the line of sight and level line at particular place is called the curvature correction
- The effect of curvature is to cause the object sighted to appear lower than they really are.
- Curvature correction is always Subtractive (-)
- True staff reading= (Observed staff reading-  $0.0785 D^2$ ) m
- Where D= distance in Km.

# Curvature Correction

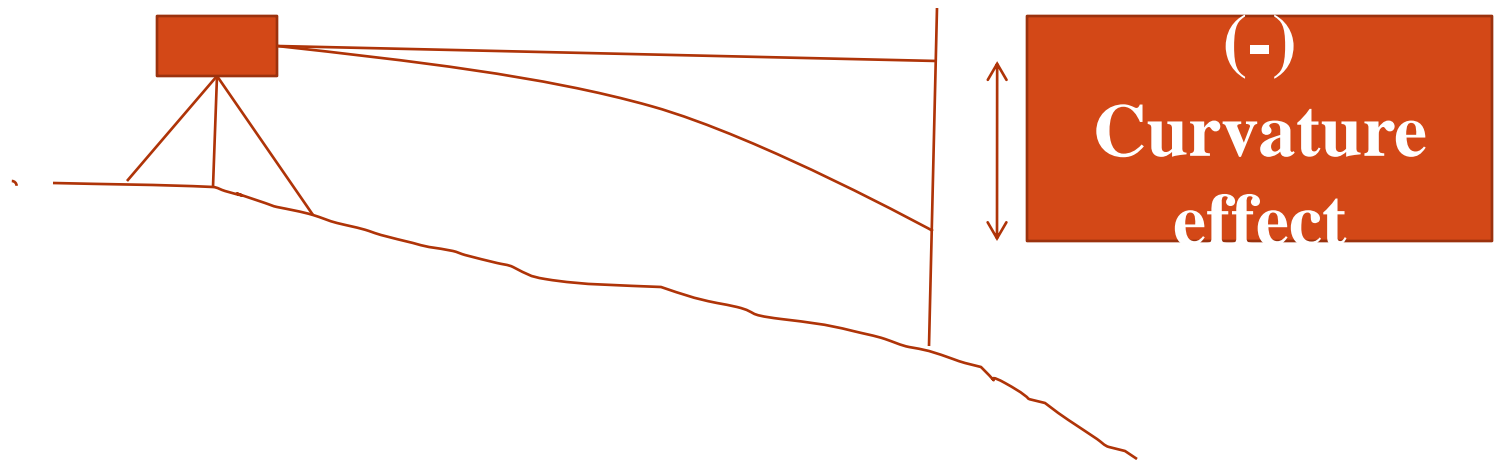

# Refraction

- The ray of light pass through layers of air of different densities and refract or bent down. The effect of refraction is to make the object appear higher then they really are. Refraction varies considerably with climate conditions.
- However it is taken as
- $C_r = 0.0112 D^2 \text{ m (+)}$
- Refraction is always additive
- True staff reading = Observed staff reading + Refraction correction.



# Refraction

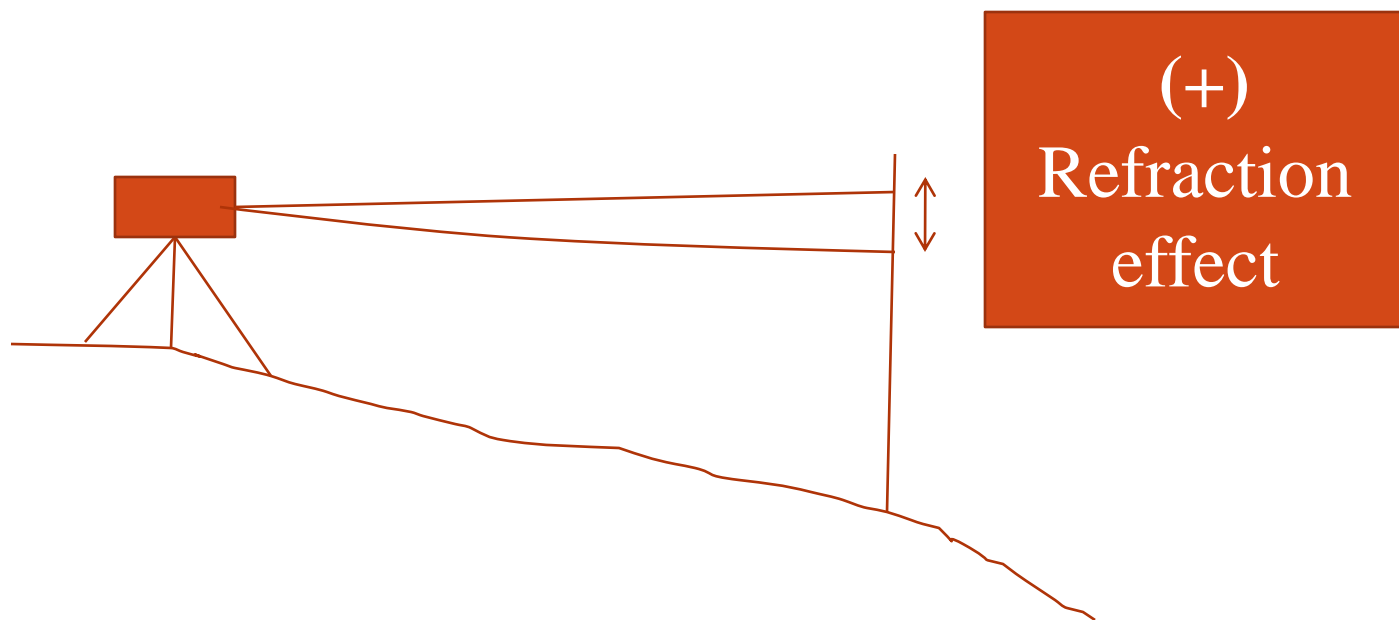

● thanks